

**FUJITSU FLASH
MCU Programmer for
F²MC-8FX
Specifications**

FUJITSU FLASH
MCU Programmer for F²MC-8FX
Specifications
Version 1.70 12 September 2008
Software version: V01L08
©2002 FUJITSU LIMITED Printed in Japan

1. Circuit diagrams utilizing Fujitsu products are included as a mean of illustrating typical semiconductor applications. Complete information sufficient for construction purposes is not necessarily given.
2. The information contained in this document has been carefully checked and is believed to be reliable. However, Fujitsu assumes no responsibility for inaccuracies.
3. The information contained in this document does not convey any license under the copy right, patent right to trademarks claimed and owned by Fujitsu.
4. Fujitsu reserved the right to change products or specifications without notice.
5. No part of this publication may be copied or reproduced in any form or by any means, or transferred to any third party without prior written consent of Fujitsu.
6. The products described in this document are not intended for use in equipment requiring high reliability, such as marine relays and medical life-support systems. For such applications, contact your Fujitsu sales representative.
7. If the products and technologies described in this document are controlled by the Foreign Exchange and Foreign Trade Control Act established in Japan, their export is subject to prior approval based on the said act.

Ver	date	page	contents
1.60	2008/07/11	P2,P4,P8 P13	ADD MB95F116M,MB95F166 OS:Windows 2000 SP3, Windows XP SP2 COM PORT 1-20
1.70	2008/09/12	P2,P4,P7,P8 P10,P17	Suffix change Caution change

CONTENTS

1. CONFIGURATION DIAGRAM.....	1
2. COMPATIBLE MICROCONTROLLERS	2
3. EXAMPLE OF CONNECTION FOR ON-BOARD REPROGRAMMING BY PROGRAMMER	3
4. PINS USED FOR ON-BOARD REPROGRAMMING	4
5. TIMING CHART FOR EACH PIN	5
6. INSTALLATION AND EXECUTION OF SOFTWARE	6
7. PROGRAMMER FUNCTIONS	7
7.1 Downloading.....	8
7.2 Erasing and Programming	10
7.3 Internal motorola S decoder specification	12
8. STATUS OF OPERATION CHECK.....	13
9. OTHERS.....	14
10. CAUTIONS.....	17

1. CONFIGURATION DIAGRAM

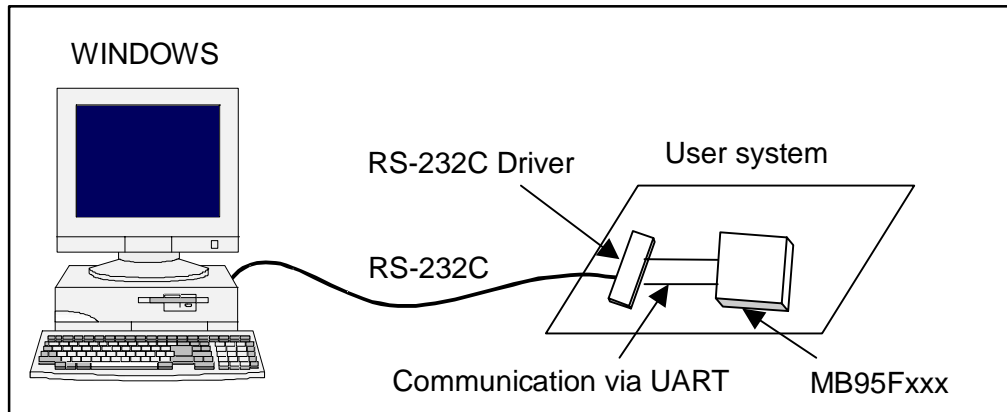

Using RS-232C cable connected to the personal computer (Windows PC), flash memory data in the microcontroller mounted in the user system can be reprogrammed. Note that the user system must have an RS-232C driver for communication with the microcontroller UART.

2. COMPATIBLE MICROCONTROLLERS

MB95F108B/AM

MB95F136MB

MB95F168MA

MB95F118B/M

MB95F146

MB95F116MA

MB95F128/MB

MB95F156M

MB95F166

3. EXAMPLE OF CONNECTION FOR ON-BOARD REPROGRAMMING BY PROGRAMMER

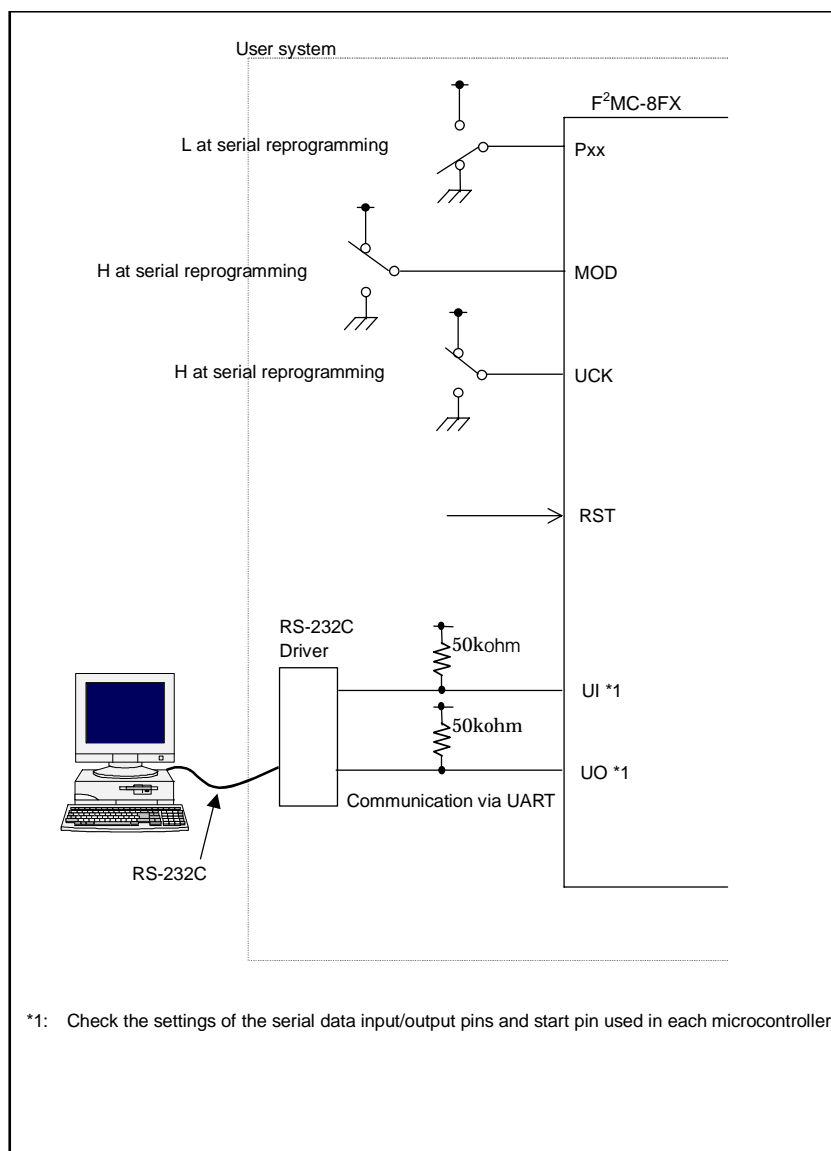

The mode pins(MOD pins), Pxx pin, and UCK pin cannot be controlled by the PC and should be set in the user system.

When the RST pin is set from “Low” to “High” level after setting the mode pins, Pxx pin, and UCK pin, the microcontroller enters the serial reprogramming mode, enabling serial reprogramming from the PC.

After the reprogramming, control is shifted to the normally-used mode as for mode pins and to the user circuit side as for Pxx pin. Then setting from “Low” to “High” level executes user program.

4. PINS USED FOR ON-BOARD REPROGRAMMING

(1) Control pins for on-board programming

Pin	Function	Supplementary Explanation
MOD	Mode pins	Should be controlled in flash reprogramming mode When MOD is set to "H", they enter the reprogramming mode.
Pxx	For setting programming mode	P13 = L
UCK	For setting serial clock	P12/UCK0 = H (pullup)
RST	Reset pin	Cancel reset after setting mode pins and Pxx to the flash reprogramming mode.
UI	Serial data input pin	Note that the pin varies with the type of microcontroller.
UO	Serial data output pin	Note that the pin varies with the type of microcontroller.

(2) Serial data I/O pins and start pins for each type of microcontroller

Type	Serial Data Input Pin	Serial Data Output Pin	Other Setting Pins	Supply Voltage
MB95F108B	P10/UI0	P11/UO0	P12/UCK0=H P13=L	3V
MB95F108AM	P10/UI0	P11/UO0	P12/UCK0=H P13=L	5V
MB95F116MA	P10/UI0	P11/UO0	P12/UCK0=H P13=L	5V
MB95F118B	P10/UI0	P11/UO0	P12/UCK0=H P13=L	3V
MB95F118M	P10/UI0	P11/UO0	P12/UCK0=H P13=L	5V
MB95F128	P10/UI0	P11/UO0	P12/UCK0=H P13=L	3V
MB95F128MB	P10/UI0	P11/UO0	P12/UCK0=H P13=L	5V
MB95F136MB	P10/UI0	P11/UO0	P12/UCK0=H P13=L	5V
MB95F146	P10/UI0	P11/UO0	P12/UCK0=H P13=L	3V
MB95F156M	P10/UI0	P11/UO0	P12/UCK0=H P13=L	5V
MB95F166	P10/UI0	P11/UO0	P12/UCK0=H P13=L	3V
MB95F168MA	P10/UI0	P11/UO0	P12/UCK0=H P13=L	5V

5. TIMING CHART FOR EACH PIN

Input data to each pin of the microcontroller with the following timing on the basis of the input of the RST pin.

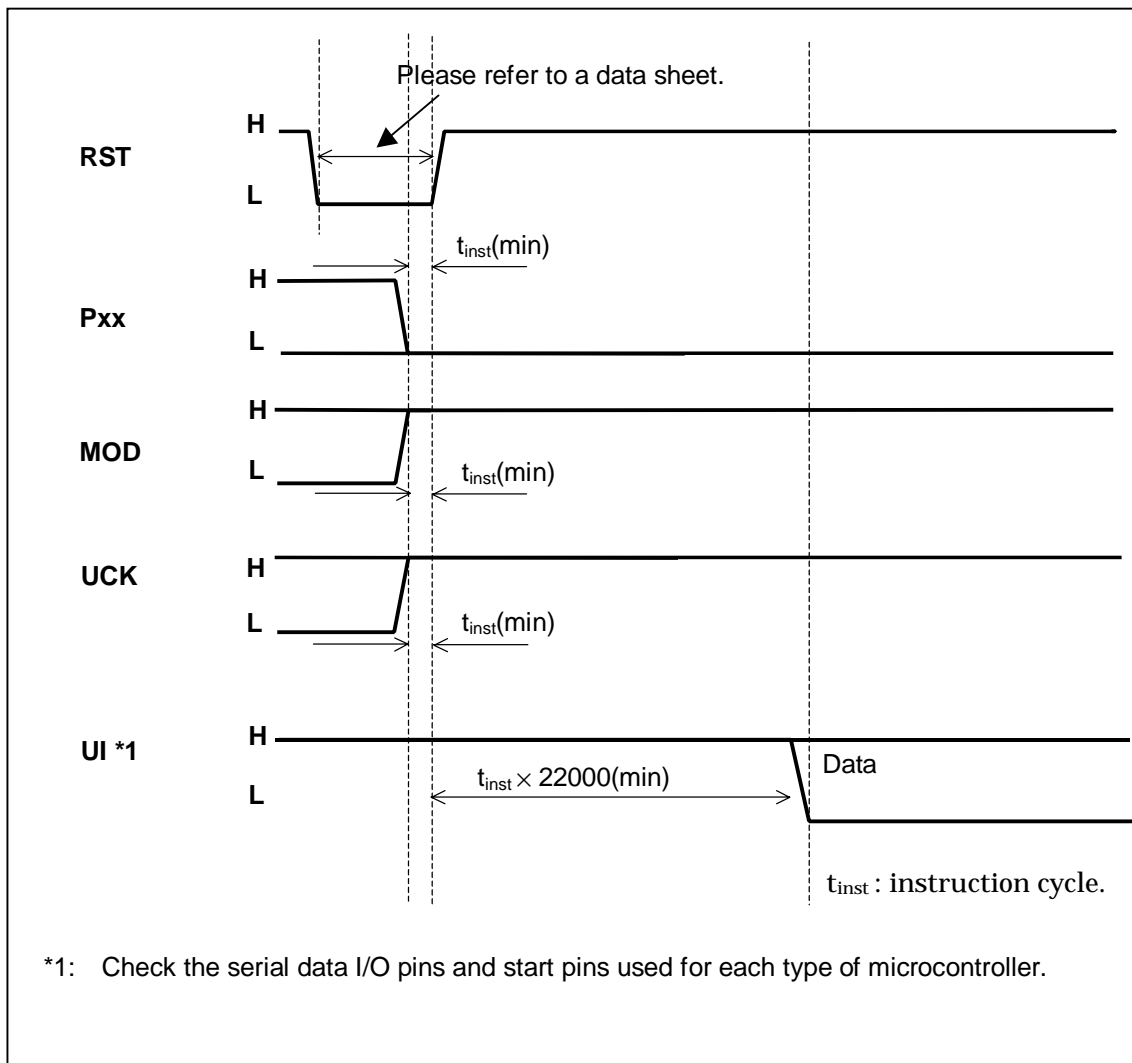

Minimum values of setup and hold times of each signal on rising edge of RST

6. INSTALLATION AND EXECUTION OF SOFTWARE

If the old software version is installed, uninstall it first before installation.

Starting the installer to operate as instructed will complete the installation. Note that the install might not be performed when a directory in a deep nest is specified as the install directory.

After installation, click the Windows **Start** button => **Program** => **FUJITSU FLASH MCU Programmer** => **FMC8FX** to start the programmer software.

7. PROGRAMMER FUNCTIONS

This programmer automatically performs erasing, programming, reading, verifying, blank checking and a set of commands for flash memory at one time.

- Main dialog box

Programmer software is started to open the dialog box as shown below.

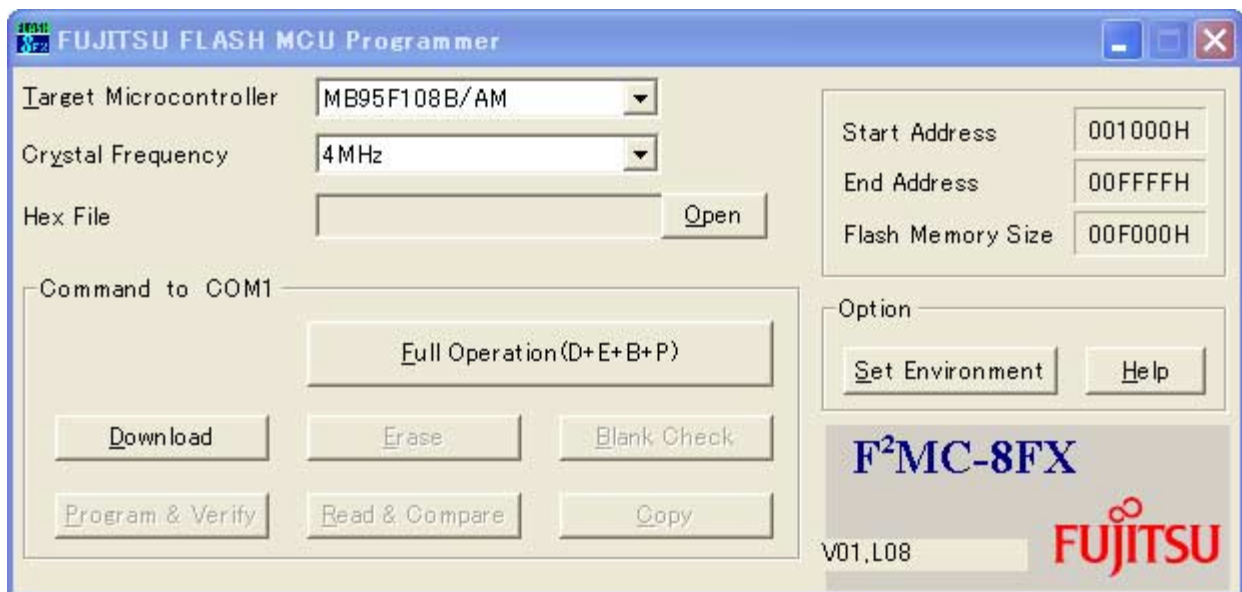

- Overview of operating procedure

First, complete setting of the user system (microcontroller board) that data is programmed to (see **Chapter 3**). In starting or when setting has been changed, it is necessary to perform downloading (described later).

After downloading terminates normally, perform procedures such as Erase and Programming.

7.1 Downloading

This section describes the operating procedure for downloading and the operating state of the program.

- (a) Specify the type of microcontroller used in the user system in **Target Microcontroller** of the main dialog box.

Note: To select the type of microcontroller, use the **Tab** key to move to **Target Microcontroller**, select with the cursor keys ↑ and ↓ and then press the **Enter** key.

- (b) Specify the frequency of the crystal oscillator input to the microcontroller in **Crystal Frequency** of the main dialog box.

The frequency of the crystal oscillator that can be specified for each type of microcontroller is limited as follows.

Product Type	Frequency of Crystal Oscillator (MHz)
MB95F108B/AM MB95F116MA MB95F118B/M MB95F128/MB MB95F136MB MB95F146 MB95F156M MB95F166 MB95F168MA	1MHz, 2MHz, 3MHz, 3.58MHz, 4MHz, 4.92MHz, 5MHz, 6MHz, 8MHz, 10MHz, 12MHz, 16MHz, 20MHz

Notice: This program will not operate normally if the microcontroller uses a crystal oscillator frequency not listed in the above table.

- (c) Select the COM port of the PC connected to the user system.

Click the **[Set Environment]** button in the main dialog box to open the setup window. When the **[COM PORT]** tab in the setup window is clicked, the specifying window is opened. Select any of the following COM ports.

COM1, COM2, COM3, COM4, COM5, COM6, COM7, COM8, COM9, COM10

COM11, COM12, COM13, COM14, COM15, COM16, COM17, COM18, COM19, COM20

(d) Execution of downloading.

Click the **[Download]** button.

If the following dialog window is opened, Input a reset signal to the microcontroller to start the program in the flash programming mode and then click the **[OK]** button

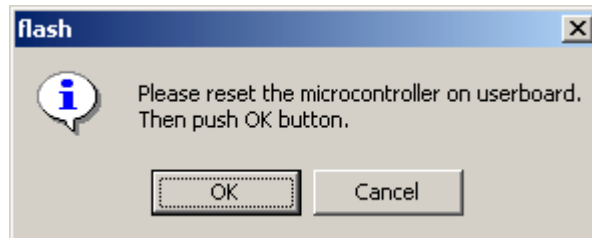

Downloading is performed to open the "Download" window. When downloading is completed normally, the following dialog window opens.

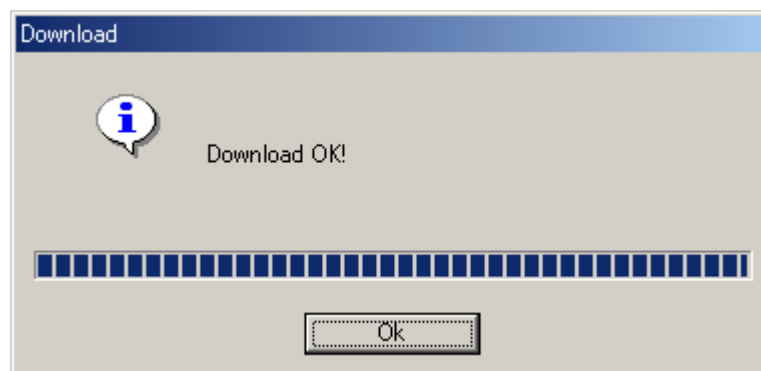

When the **[OK]** button is clicked to close the dialog window, the **[Erase]**, **[Blank Check]**, **[Program & Verify]**, **[Read & Compare]** and **[Copy]** buttons are enabled.

Note: Downloading can also be performed using the **Tab** key to move to the **[Download]** button and pressing the **Enter** key or pressing the **ALT** and **D** keys at the same time.

7.2 Erasing and Programming

This section explains how to specify **Hex File** and the processing and operation performed when the **[Erase]**, **[Blank Check]**, **[Program & Verify]**, **[Read & Compare]**, **[Copy]** and **[Full Operation (D+E+B+P)]** buttons are clicked.

Each execution can also be performed by pressing the key corresponding to the underlined character in the button name while pressing the **ALT** key. (**Hex File** is a **O** character in **Open** button, click the **ALT + O** keys).

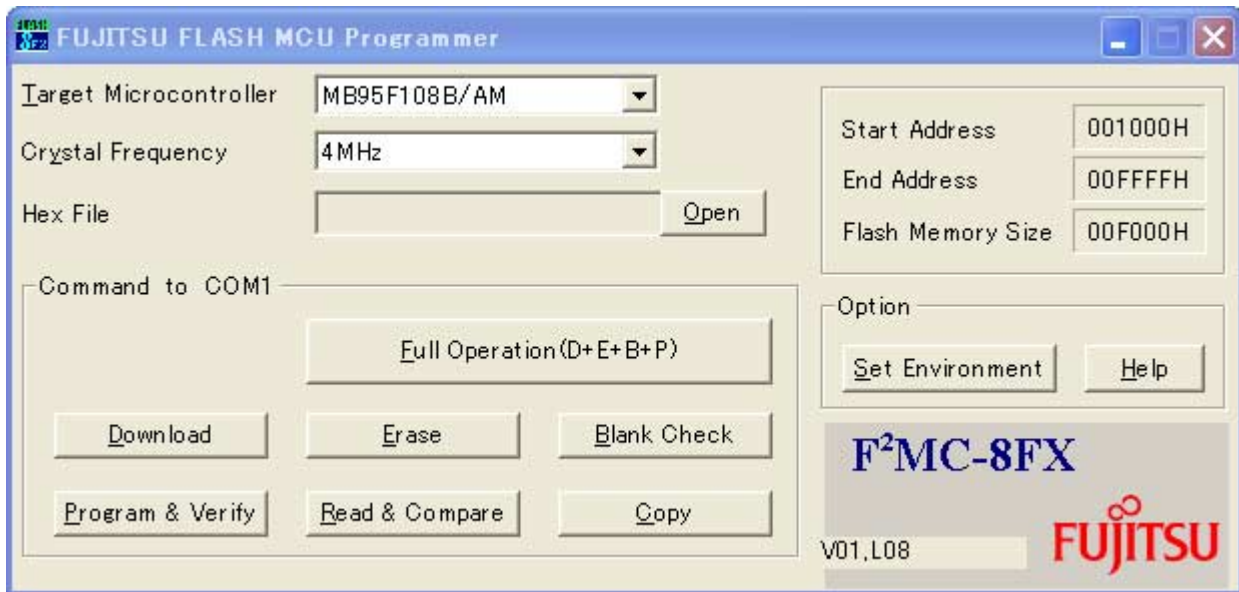

- (a) **Hex File:** Select the file to be programmed to flash memory

Specify the Motorola-S format file to be programmed to flash memory in the microcontroller. Drag and drop the file directly from Internet Explorer or click the **[Open]** button to open the file select window.

Hex File must be specified to execute **[Program & Verify]**, **[Read & Compare]** and **[Full Operation (D+E+B+P)]**. Since it is decoded at the head of these processings each time, even if the specified Motorola S format file changes specification of a file just before processing, it is OK.

- (b) **Erase:** Erase all flash memory areas

All flash memory must be in the erase state (0xff) when programming a new program to it. By pushing this button, a chip erase command is published to FLASH and elimination is performed.

In addition, a blank check does not perform this command.

- (c) **Blank Check:** Check that all flash memory areas are blank

This button is clicked to check that all flash memory is in the erase state (0xff).

(d) **Program & Verify:** Program data to flash memory

his button is clicked to program the Motorola-S format file specified in **Hex File** to flash memory in the microcontroller concurrently with verification. An error dialog is displayed, when writing is performed for 256 bytes of every block and a CRC error is detected by the block.

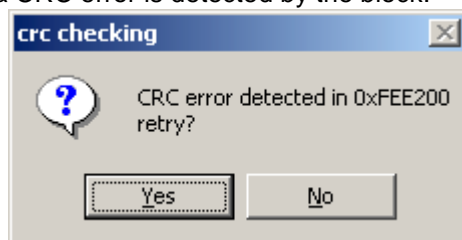

This dialog If YES is pushed, the block of an error will be resent and it will continue writing. A push on NO interrupts write-in processing.

(e) **Read & Compare:** Compare **Hex File** with data in flash memory in microcontroller

This button is clicked to compare data in the Motorola-S format file specified in **Hex File** with data in flash memory in the microcontroller. Like the **[Program & Verify]** processing, The data of FLASH is transmitted for 256 bytes of every block, a CRC error check is performed, and comparison processing is performed.

(f) **Copy:** Save data in flash memory in microcontroller to file

This button is clicked to read data from flash memory integrated into the microcontroller and save it as an Motorola-S format file. Like **[Read & Compare]** processing, FLASH memory reading is performed for 256 bytes of every block, and a CRC error check is performed similarly. A preservation place folder is specified, and if a file name is inputted and **[Save]** button is pushed, processing will begin.

(g) **Full Operation (D+E+B+P):** Automatic programming

Operation to **[Download]** to **[Program & Verify]** is performed by package.

In the case of a blank chip, processing is performed in order of **[Download]**, **[Blankcheck]**, and **[Program & Verify]**. When it is not a blank chip, processing is performed in order of **[Download]**, **[Blankcheck]**, **[Erase]**, **[Blankcheck]**, and **[Program & Verify]**.

7.3 Internal motorola S decoder specification

tbd

8. STATUS OF OPERATION CHECK

- Specifications for PC used for operation check

PC: FMV 6450TX2

CPU: Pentium 450 MHz

OS: Japanese and English version of Windows 2000 SP3, Windows XP SP2

Memory: 192 MB

9. OTHERS

(A) Setting of voice output

The setting of voice generated when an error occurs and processing is terminated normally can be changed.

Select the **[Sound]** tab in the setup window that opens when the **[Set Environment]** button is clicked.

- To output sound, put a check in the **Use sound** checkbox.
- Next, the event to take out sound is chosen in the Event column, and the sound in the event is set up by specifying SoundType and WaveFile under it in the state.
- Select **Wave** or **Beep** as the type of sound to be output in **Sound type**.
- Set the voice file to be output in the **Wave** file column only when **Wave** is selected. When the **[Open]** button is clicked, the File Open window is opened. Select the **Wave** file to be output. The **[Play]** button is used to play the set **Wave** file. The **[Stop]** button is used to stop the **Wave** file.

(B) Setting of tooltips display

The tooltips display can be either “enabled” or “disabled”.

Select the **[Tooltips]** tab in the setup window that opens when the **[Set Environment]** button is clicked.

When a checkmark is put in the **tooltips** checkbox to move the mouse cursor over the contents such as buttons in the dialog window, simple help (the full path of a file for Hex File) is displayed.

(C) about error messages

Many error messages are displayed owing to the setting mistake of hardware and software. the case where an error is outputted in addition even if it checks these in detail, please tell the person in charge of software acquisition origin a detailed condition.

No.	Item	Description
No.001	Message	Download error *1
	Cause	The response of download processing is unusual.
	Action	Please check connection and a setup of hardware.
No.003	Message	Timeout error
	Cause	The response of a command does not come on the contrary.
	Action	Please check connection and a setup of hardware.
No.006	Message	Unable to open COM port
	Cause	Another application is using COM.
	Action	Please check the use situation and port number of a COM port.
No.007	Message	Unable to open Download file
	Cause	<code>m_flash.xxx</code> not found
	Action	Please reinstall this software.
No.009	Message	Unable to gain COM port info
	Cause	It will be in the state where the target COM port can be used.
	Action	Please check the number of a COM port and setup to be used.
No.010	Message	Unable to change COM port setting
	Cause	A communication setup cannot be set as the target COM port.
	Action	Please inform support of condition.
No.011	Message	Communication error
	Cause	The unusual command response was received.
	Action	Please reperform by improving connection and a setup of hardware.
No.012	Message	Read error
	Cause	The response at the time of read&compare or copy processing is unusual.
	Action	Please reperform by improving connection and a setup of hardware.
No.013	Message	Program error
	Cause	The response at the time of Program&Verify processing is unusual.
	Action	Please reperform by checking whether a chip is blank.
No.015	Message	COM port write error
	Cause	There is the possibility of the abnormalities of a COM port driver or the port itself.
	Action	Please inform support of condition.

No.	Item	Description
No.016	Message	COM port read error
	Cause	There is the possibility of the abnormalities of a COM port driver or the port itself.
	Action	Please inform support of condition.
No.017	Message	File access error
	Cause	Access of a m_flash.xxx file went wrong.
	Action	Return the folder and file configurations to the installation defaults.
No.018	Message	Erase error *1
	Cause	The response at the time of erase processing is unusual. There is the possibility that a chip is poor.
	Action	Please improve a setup of hardware or exchange chips.
No.019	Message	Connect error
	Cause	The response of Connect processing is unusual.
	Action	Please improve a setup of hardware or exchange chips.
No.101	Message	Please set "hex file"
	Cause	"Hex file" not set
	Action	Set "hex file" in the dialog box.
No.207	Message	memory is not available
	Cause	Unable to allocate memory for execution
	Action	Quit any running application and retry.
*2	Message	Please redo from download operation
*3	Message	Connect failed.

*1: "MCU xxH" is displayed if the error cause is returned from the microcontroller at a download error.

"MCU xxH" means:

MCU 02H → SUM error at downloading

MCU 04H → Abnormal termination at downloading

*2: This is an additional message. It is displayed as necessary after other messages are displayed.

*3: This is an additional message. Please improve a setup of hardware or exchange chips.

10. CAUTIONS

The PC programming software has the possibility of receiving the influence by the communications cable, the outside environment, and the PC.

Therefore, please evaluate it enough when you use the software.

Please use programming systems of programmer venders when you write two or more devices at the same time.

Please don't use the USB HUB between PC and MCU.

The specifications of the product are subject to change without notice.