

FPT-176P-M07

<p>176-pin plastic LQFP</p>  <p>(FPT-176P-M07)</p>	Lead pitch	0.50 mm
	Package width × package length	24.0 × 24.0 mm
	Lead shape	Gullwing
	Sealing method	Plastic mold
	Mounting height	1.70 mm MAX
	Code (Reference)	P-LQFP-0176-2424-0.50

176-pin plastic LQFP
(FPT-176P-M07)

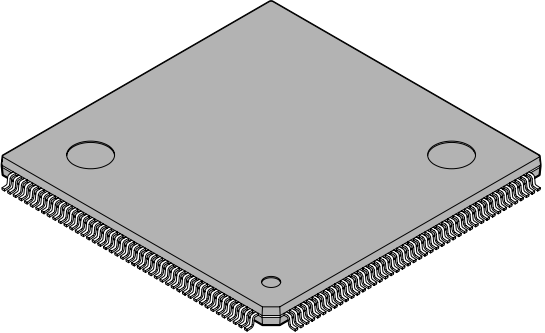
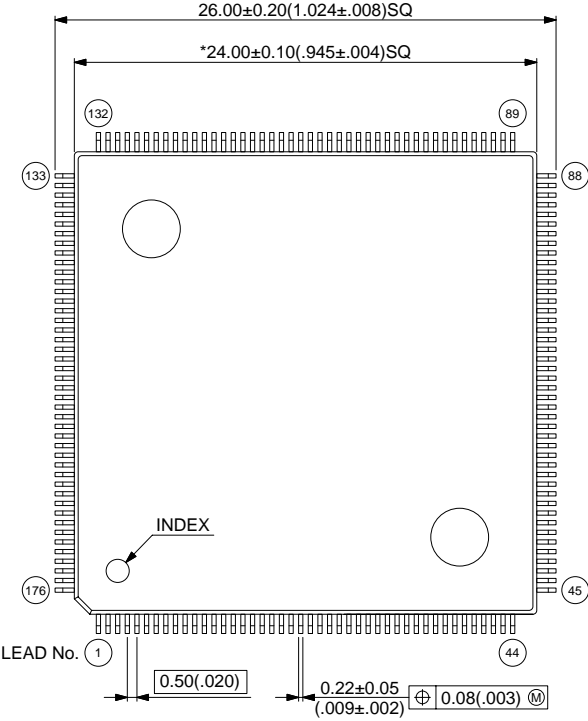

LEAD No. 1

Note 1) * : Values do not include resin protrusion.
Resin protrusion is +0.25(.010)Max(each side).

Note 2) Pins width and pins thickness include plating thickness

Note 3) Pins width do not include tie bar cutting remainder.

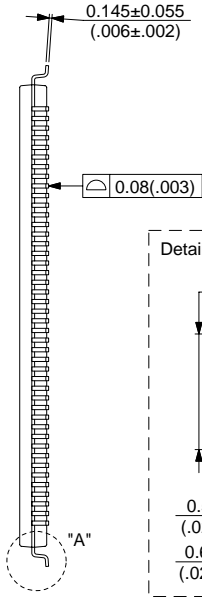

Details of "A" part

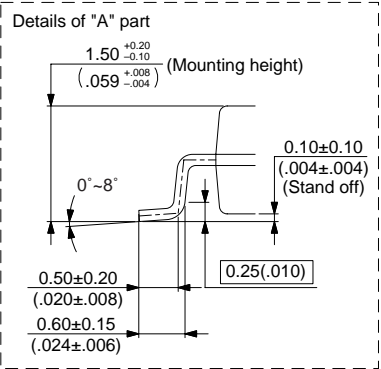

© 2004 FUJITSU LIMITED F176013S-c-1-1

Dimensions in mm (inches).
Note: The values in parentheses are reference values.

The contents of this document are subject to change without notice.
Customers are advised to consult with FUJITSU sales representatives before ordering.
FUJITSU is unable to assume responsibility for infringement of any patent rights or other rights of third parties arising from the use of the information or package dimensions in this document.