

FR FAMILY
32-BIT MICROCONTROLLER
MB91460

CLOCK SUPERVISOR

APPLICATION NOTE

Revision History

Date	Issue
2008-06-18	V1.0, First draft, HPI
2009-08-28	V1.1, MSt Added information of feature in new devices, RCE bit description corrected

This document contains 12 pages.

Warranty and Disclaimer

To the maximum extent permitted by applicable law, Fujitsu Microelectronics Europe GmbH restricts its warranties and its liability for **all products delivered free of charge** (eg. software include or header files, application examples, target boards, evaluation boards, engineering samples of IC's etc.), its performance and any consequential damages, on the use of the Product in accordance with (i) the terms of the License Agreement and the Sale and Purchase Agreement under which agreements the Product has been delivered, (ii) the technical descriptions and (iii) all accompanying written materials. In addition, to the maximum extent permitted by applicable law, Fujitsu Microelectronics Europe GmbH disclaims all warranties and liabilities for the performance of the Product and any consequential damages in cases of unauthorised decompiling and/or reverse engineering and/or disassembling. **Note, all these products are intended and must only be used in an evaluation laboratory environment.**

1. Fujitsu Microelectronics Europe GmbH warrants that the Product will perform substantially in accordance with the accompanying written materials for a period of 90 days from the date of receipt by the customer. Concerning the hardware components of the Product, Fujitsu Microelectronics Europe GmbH warrants that the Product will be free from defects in material and workmanship under use and service as specified in the accompanying written materials for a duration of 1 year from the date of receipt by the customer.
2. Should a Product turn out to be defect, Fujitsu Microelectronics Europe GmbH's entire liability and the customer's exclusive remedy shall be, at Fujitsu Microelectronics Europe GmbH's sole discretion, either return of the purchase price and the license fee, or replacement of the Product or parts thereof, if the Product is returned to Fujitsu Microelectronics Europe GmbH in original packing and without further defects resulting from the customer's use or the transport. However, this warranty is excluded if the defect has resulted from an accident not attributable to Fujitsu Microelectronics Europe GmbH, or abuse or misapplication attributable to the customer or any other third party not relating to Fujitsu Microelectronics Europe GmbH.
3. To the maximum extent permitted by applicable law Fujitsu Microelectronics Europe GmbH disclaims all other warranties, whether expressed or implied, in particular, but not limited to, warranties of merchantability and fitness for a particular purpose for which the Product is not designated.
4. To the maximum extent permitted by applicable law, Fujitsu Microelectronics Europe GmbH's and its suppliers' liability is restricted to intention and gross negligence.

NO LIABILITY FOR CONSEQUENTIAL DAMAGES

To the maximum extent permitted by applicable law, in no event shall Fujitsu Microelectronics Europe GmbH and its suppliers be liable for any damages whatsoever (including but without limitation, consequential and/or indirect damages for personal injury, assets of substantial value, loss of profits, interruption of business operation, loss of information, or any other monetary or pecuniary loss) arising from the use of the Product.

Should one of the above stipulations be or become invalid and/or unenforceable, the remaining stipulations shall stay in full effect

Contents

REVISION HISTORY	2
WARRANTY AND DISCLAIMER	3
CONTENTS	4
1 INTRODUCTION	5
2 CLOCK SUPERVISOR	6
2.1 Overview	6
2.2 Registers	7
2.2.1 Clock Supervisor Control Register (CSVCR)	7
2.3 Operation Modes	8
2.3.1 Operation mode with initial settings	8
2.3.2 Disabling the clock supervisors	8
2.3.3 Re-enabling the clock supervisors	8
2.3.4 Enabling / Disabling RC-oscillator in STOP mode	8
2.3.5 Clock Supervisor in STOP mode	9
2.3.6 Switching back from RC Oscillation to Clock Oscillation	9
2.3.6.1 Switching back from RC–Oscillation to Main Oscillation	9
2.3.6.2 Switching back from RC–Oscillation to Sub Oscillation	9
3 CLOCK SUPERVISOR EXAMPLE	10
3.1 Enabling and Disabling RC Oscillator in STOP mode	10
3.2 Enabling and Disabling Main Clock and Sub Clock Supervisor	10
4 ADDITIONAL INFORMATION	11
LIST OF FIGURES	12

1 Introduction

This application note gives an overview of the Clock Supervisor.

Purpose of the Clock Supervisor is the supervision of the Main and Sub oscillators. In case of oscillation (`OSCMAIN` or `OSCSUB`) failure the Clock Supervisor control logic will take action, i.e. switching to an internal RC-oscillation clock (`CLKRC` 100 kHz), depending on the operation mode set in the control register.

2 Clock Supervisor

This chapter explains the Clock Supervisor in detail.

2.1 Overview

There are two independent supervisors one for the Main clock and one for the Sub clock. They can be enabled/ disabled separately.

Main clock and Sub clock supervisor are disabled and re-enabled automatically if the corresponding oscillator is disabled and re-enabled.

There are two status bits in the Clock Supervisor Control Register which indicate the failure of the Main clock and Sub clock. These bits can be available at two port pins (device dependent).

If a clock used by MCU fails for a certain time (20-80 μ s for Main clock / 160-640 μ s for Sub clock) the MCU is reset and the reset cause can be checked after reset vector fetch.

To find out whether the Clock Supervisor has asserted reset, the software must check the reset cause by reading the `RSRR` register. If `INIT` (bit 7 of `RSRR`) is set, the cause was either external reset at the `INITX` pin or the clock supervisor. If neither `SM` bit nor `MM` bit (bit 5 and bit 6 of `CSVCR`) is set, reset cause was the external reset. If `SM` is '1' the reset cause is a missing Sub clock and if `MM` is '1' the reset cause is a missing Main clock.

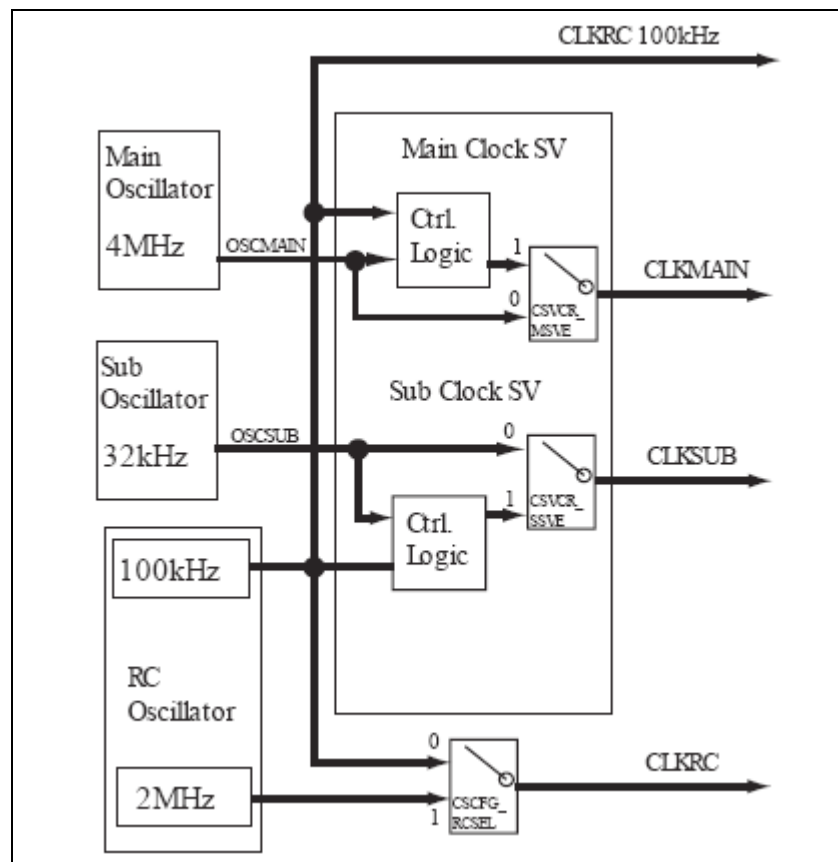

Figure 2-1: Block Diagram of Clock Supervisor

2.2 Registers

This section lists the Clock Supervisor Control Register and describes the function of each bit in detail.

2.2.1 Clock Supervisor Control Register (CSVCR)

The Clock Supervisor Control Register (CSVCR) sets the operation mode of the Clock Supervisor.

Bit No.	Name	Explanation	Initial Value	Value	Operation
0	OUTE	Output enable*	0	0	Do not enable ports for MCLK_MISSING and SCLK_MISSING output pins
				1	Enable ports for MCLK_MISSING and SCLK_MISSING output pins
1	SRST	Sub clock mode reset	0	0	Do not perform reset upon transition from Main clock to Sub clock modes if Sub clock is already missing
				1	Perform reset upon transition from Main clock to Sub clock modes if Sub clock is already missing
2	SSVE	Sub clock supervisor enable	1	0	Disable Sub clock supervisor
				1	Enable Sub clock supervisor
3	MSVE	Main clock supervisor enable	1	0	Disable Main clock supervisor
				1	Enable Main clock supervisor
4	RCE	RC oscillator enable	1	0	Disable RC-oscillator in STOP mode
				1	Enable RC-oscillator in STOP mode
5	SM	Sub clock missing	0	0	Missing Sub clock has not been detected
				1	Missing Sub clock has been detected
6	MM	Main clock missing	0	0	Missing Main clock has not been detected
				1	Missing Main clock has been detected
7	SCKS	Sub clock select (only used for single clock devices)	0	0	32k oscillation used as Sub clock
				1	RC oscillation used as Sub clock

*Note: This bit can be used as an output enable to output the signals MCLK_MISSING (bit 3 of CSVCR) and SCLK_MISSING (bit 4 of CSVCR) to port pins. For MB9F1460D series it is available at Pin number 3 and 2 respectively.

For more information about the pins see the corresponding Datasheet.

2.3 Operation Modes

2.3.1 Operation mode with initial settings

In case the clock supervisor control register (CSVCR) is not configured at the beginning of the user program, the RC-oscillator, the Main clock supervisor and the Sub clock supervisor is enabled.

The Main clock supervisor is enabled after the 'oscillation stabilization wait time' or in case the Main clock is missing before the completion of the 'oscillation stabilization wait time', after the 'Main clock timeout' (TO_MCLK) from the timeout counter. (The timeout counter is clocked with CLKRC) If the Main clock is missing from power-on, the power-on reset state is never left, which in this case is a safe state. The user must make sure with external pull-up/pull-down resistors that all relevant signals are pulled to the correct level.

The Sub clock supervisor is enabled after the completion of the 'Sub clock timeout' (TO_SCLK) from the timeout counter.

If the Main clock stops while the Main clock supervisor is enabled, the Main clock is replaced with CLKRC 100kHz, the MM bit is set to '1' and reset (EXT_RST_OUT) is asserted.

If the Sub clock stops and if the Sub clock supervisor is enabled, the behavior depends on whether the MCU is in Main clock mode or in Sub clock mode. If the Sub clock stops in Sub clock mode, CLKRC divided by two substitutes the Sub clock, the SM bit is set to '1' and reset (EXT_RST_OUT) is asserted. If the Sub clock stops in Main clock mode, CLKRC divided by two substitutes the Sub clock, the SM bit is set to '1' and no reset occurs upon transition to Sub clock mode, since the SRST bit has its initial value of '0'. If the SRST bit is '1' a reset (INIT) occurs.

If a clock missing was detected, the Application cannot change back to MAIN or Sub clock operation. The MM or SM bit are read-only bits. Only external INIT reset at pin INITX will reset the condition.

2.3.2 Disabling the clock supervisors

If clock supervision is not required or sub clock is not used / connected to the device it is possible to disable the supervision of each clock.

The Main clock supervisor is disabled by setting MSVE (bit 3 of CSVCR) to '0'.

The Sub clock supervisor is disabled by setting SSVE (bit 2 of CSVCR) to '0'.

2.3.3 Re-enabling the clock supervisors

The Main clock supervisor is enabled by setting MSVE (bit 3 of CSVCR) to '1'.

The Sub clock supervisor is enabled by setting SSVE (bit 2 of CSVCR) to '1'.

2.3.4 Enabling / Disabling RC-oscillator in STOP mode

It is possible to select if RC-Oscillator is enabled or disabled in STOP mode. In all other modes the RC-oscillator is always enabled. When entering STOP mode the RCE bit is checked an RC-Oscillator is stopped or remains running. In case of a wakeup event in STOP mode the RC-Oscillator is activated automatically (if RCE bit is set to '0').

Disabling the RC-oscillator in STOP mode is done by setting bit RCE (bit 4 of CSVCR) to '0'. Enabling the RC-oscillator in STOP mode is done by setting bit RCE (bit 4 of CSVCR) to '1'.

Note:

In some devices of MB91460 series it is possible to select if Hardware Watchdog is enabled in STOP mode. If this is enabled, the RC-oscillator is enabled in STOP mode, independent from `RCE` value. See datasheet if this feature is supported.

2.3.5 Clock Supervisor in STOP mode

If RC-oscillator, Main clock and Sub clock supervisors are automatically disabled at transition into STOP mode if they are enabled already. The corresponding enable bits in the clock supervisor control register remain unchanged. So after wake-up from STOP mode the RC-oscillator and the clock supervisors will be enabled again.

If the corresponding enable bits are set to '0', the clock supervisors will stay disabled after wake-up from STOP mode.

The RC-oscillator is enabled immediately after wake-up from STOP mode.

The Main clock supervisor is enabled after the 'oscillation stabilization wait time' or in case the Main clock is missing after wake-up from STOP mode, after the 'Main clock timeout' (`TO_MCLK`) from the timeout counter which is clocked with the CLKRC.

The Sub clock supervisor is enabled after the 'Sub clock timeout' (`TO_SCLK`) from the timeout counter which is clocked with the CLKRC.

2.3.6 Switching back from RC Oscillation to Clock Oscillation

In some devices of MB91460 series it is possible to switch back from RC-oscillator in case a clock miss was detected without asserting external INITX reset at the pin. Check corresponding Datasheet if this feature is supported.

2.3.6.1 Switching back from RC–Oscillation to Main Oscillation

In case of MAIN clock miss the clock source is switched to RC-Oscillation and a Reset is asserted. The Application can check the reset cause during init phase the `RSRR` and `CSVCR` register to find out the reset cause. In case the `MM` bit is set to 1 in `CSVCR` register a Main clock miss was detected. It is possible to switch back to MAIN Oscillator by clearing bit `MM` in `CSVCR` register. In case the main clock is still missing the write access to the bit is ignored and RC-Oscillator is used as clock source. In case the main clock is operating, clock source is switched from RC-Oscillator to main oscillator.

2.3.6.2 Switching back from RC–Oscillation to Sub Oscillation

MCU is running on SUB clock and a sub clock miss was detected, switching to RC-Oscillator. The `SRST` bit in `CSVCR` register set to 0, no reset is generated in case of SUB clock miss detection. It is possible to switch back to Sub Oscillation by clearing the `CM` bit in `CSVCR` register. In case the sub clock is still missing the write access to the bit is ignored and RC-Oscillator is used as clock source. In case the sub clock is operating, clock source is switched from RC-Oscillator to main oscillator.

3 Clock Supervisor Example

EXAMPLE FOR CLOCK SUPERVISOR

3.1 Enabling and Disabling RC Oscillator in STOP mode

```

/* THIS SAMPLE CODE IS PROVIDED AS IS AND IS SUBJECT TO ALTERATIONS. FUJITSU */
/* MICROELECTRONICS ACCEPTS NO RESPONSIBILITY OR LIABILITY FOR ANY ERRORS OR */
/* ELIGIBILITY FOR ANY PURPOSES. */
/* (C) Fujitsu Microelectronics Europe GmbH */
/*-----
char Set_RCE(char state){
    if (state) {
        CSVCR_RCE = 1;           /* Enable RC Oscillator in STOP mode*/
    } else {
        CSVCR_MSVE = 0;         /* Disable Clock supervisor */
        CSVCR_SSVE = 0;
        while (CSVCR_SM == 1 || CSVCR_MM == 1){
            HWWD = 0;
        }
        CSVCR_RCE = 0;         /*Disable RC Oscillator in STOP mode*/
    }
    return 0;
}

```

3.2 Enabling and Disabling Main Clock and Sub Clock Supervisor

```

/* THIS SAMPLE CODE IS PROVIDED AS IS AND IS SUBJECT TO ALTERATIONS. FUJITSU */
/* MICROELECTRONICS ACCEPTS NO RESPONSIBILITY OR LIABILITY FOR ANY ERRORS OR */
/* ELIGIBILITY FOR ANY PURPOSES. */
/* (C) Fujitsu Microelectronics Europe GmbH */
/*-----
char Set_MSVE(char state){           /*Enable Main clock supervisor*/
    if (state)
        CSVCR_MSVE = 1;
    else
        CSVCR_MSVE = 0;
    return 0;
}

char Set_SSVE(char state){           /*Enable Sub clock supervisor*/

    if (state)
        CSVCR_SSVE = 1;
    else
        CSVCR_SSVE = 0;
    return 0;
}

```

4 Additional Information

Information about FUJITSU Microcontrollers can be found on the following Internet page:

<http://mcu.emea.fujitsu.com/>

The software examples related to this application note is:

91460_clock_supervisor

It can be found on the following Internet page:

http://mcu.emea.fujitsu.com/mcu_product/mcu_all_software.htm

List of Figures

Figure 2-1: Block Diagram of Clock Supervisor 6