

F²MC-8L FAMILY

8-BIT MICROCONTROLLER

MB89210

GETTING STARTED

APPLICATION NOTE

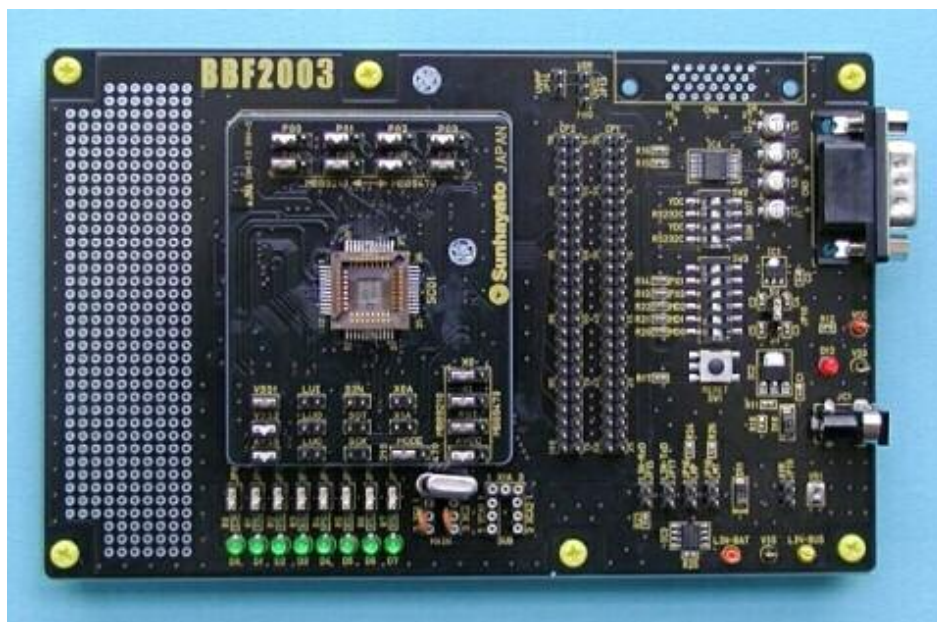

Revision History

Date	Issue
06.08.2004	V1.0, HWe, First release

This document contains 13 pages.

Warranty and Disclaimer

To the maximum extent permitted by applicable law, Fujitsu Microelectronics Europe GmbH restricts its warranties and its liability for **all products delivered free of charge** (eg. software include or header files, application examples, target boards, evaluation boards, engineering samples of IC's etc.), its performance and any consequential damages, on the use of the Product in accordance with (i) the terms of the License Agreement and the Sale and Purchase Agreement under which agreements the Product has been delivered, (ii) the technical descriptions and (iii) all accompanying written materials. In addition, to the maximum extent permitted by applicable law, Fujitsu Microelectronics Europe GmbH disclaims all warranties and liabilities for the performance of the Product and any consequential damages in cases of unauthorised decompiling and/or reverse engineering and/or disassembling. **Note, all these products are intended and must only be used in an evaluation laboratory environment.**

1. Fujitsu Microelectronics Europe GmbH warrants that the Product will perform substantially in accordance with the accompanying written materials for a period of 90 days from the date of receipt by the customer. Concerning the hardware components of the Product, Fujitsu Microelectronics Europe GmbH warrants that the Product will be free from defects in material and workmanship under use and service as specified in the accompanying written materials for a duration of 1 year from the date of receipt by the customer.
2. Should a Product turn out to be defect, Fujitsu Microelectronics Europe GmbH's entire liability and the customer's exclusive remedy shall be, at Fujitsu Microelectronics Europe GmbH's sole discretion, either return of the purchase price and the license fee, or replacement of the Product or parts thereof, if the Product is returned to Fujitsu Microelectronics Europe GmbH in original packing and without further defects resulting from the customer's use or the transport. However, this warranty is excluded if the defect has resulted from an accident not attributable to Fujitsu Microelectronics Europe GmbH, or abuse or misapplication attributable to the customer or any other third party not relating to Fujitsu Microelectronics Europe GmbH.
3. To the maximum extent permitted by applicable law Fujitsu Microelectronics Europe GmbH disclaims all other warranties, whether expressed or implied, in particular, but not limited to, warranties of merchantability and fitness for a particular purpose for which the Product is not designated.
4. To the maximum extent permitted by applicable law, Fujitsu Microelectronics Europe GmbH's and its suppliers' liability is restricted to intention and gross negligence.

NO LIABILITY FOR CONSEQUENTIAL DAMAGES

To the maximum extent permitted by applicable law, in no event shall Fujitsu Microelectronics Europe GmbH and its suppliers be liable for any damages whatsoever (including but without limitation, consequential and/or indirect damages for personal injury, assets of substantial value, loss of profits, interruption of business operation, loss of information, or any other monetary or pecuniary loss) arising from the use of the Product.

Should one of the above stipulations be or become invalid and/or unenforceable, the remaining stipulations shall stay in full effect

Contents

REVISION HISTORY	2
WARRANTY AND DISCLAIMER	3
CONTENTS	4
1 INTRODUCTION	5
1.1 Product line-up	5
1.2 Tool line-up	5
1.2.1 Evaluation board	5
1.2.2 Emulator system	5
1.2.3 Package conversion adapter	5
1.2.4 Flash programmer software	5
2 EVALUATION SYSTEM CONFIGURATION	6
2.1 Optional Sub-D9 connector for RS232-UART	7
2.2 Using the LIN-interface	8
3 SOFTWARE	9
3.1 New project	9
3.2 Flash programming	11
3.2.1 Hardware	11
3.2.2 Software	12

1 Introduction

This application note describes the development tool chain for the MB89210series.

1.1 Product line-up

The MB89210series includes the following device members:

MB89PV210	Evaluation chip	(MQP-48C-P02)
MB89215	Mask-ROM	(FPT-30P-M02, FPT-48P-M13)
MB89P215	OTP-ROM	(FPT-30P-M02)
MB89F217	Flash-ROM	(FPT-48P-M13)

1.2 Tool line-up

1.2.1 Evaluation board

The following evaluation board for the MB89210series is available from Sunhayato Corp.

BBF2003-8L-48PS	Evaluation board (Main board + Daughter board for MQP-48C-P02)
BBF2003-8L-MB	Evaluation board (Main board)
BBF2003-8L-48PB	Evaluation board (Daughter board for MB89PV210 / MQP-48C-P02)

1.2.2 Emulator system

MSE1001C	F ² MC-8L Compact ICE (In Circuit Emulator)
MB2144-203	Probe cable for use with evaluation board BBF2003-8L-48PS / -48PB

1.2.3 Package conversion adapter

The package conversion adapter allows using the evaluation chip MB89PV210 on the target system.

48QF-30SOP-8L	Package conversion adapter MQP-48C-P02 --> FPT-30P-M02
48QF2-48QF2-8L	Package conversion adapter MQP-48C-P02 --> FPT-48P-M13

1.2.4 Flash programmer software

The freeware "8bit Fujitsu Flash MCU Programmer" version V01L08 or newer can be downloaded from our webpage: <http://www.fme.gsdc.de/products/utilitie.htm>

2 Evaluation system configuration

The evaluation system BBF2003-8L-48PS for the MB89210series includes the main board BBF2003-8L-MB and the 48-pin daughter board BBF2003-8L-48PB.

The main board supports the following features

- DCin, on-board voltage regulator (+5V / +3V), power-LED
- Reset-button
- All signals routed to pin-header
- Port 0 (P00 to P07) routed via jumpers to LEDs
- UART RS232 transceiver, optional Sub-D9 connector
- LIN transceiver TJA1020

The default jumper setting for the MB89210series is shown below:

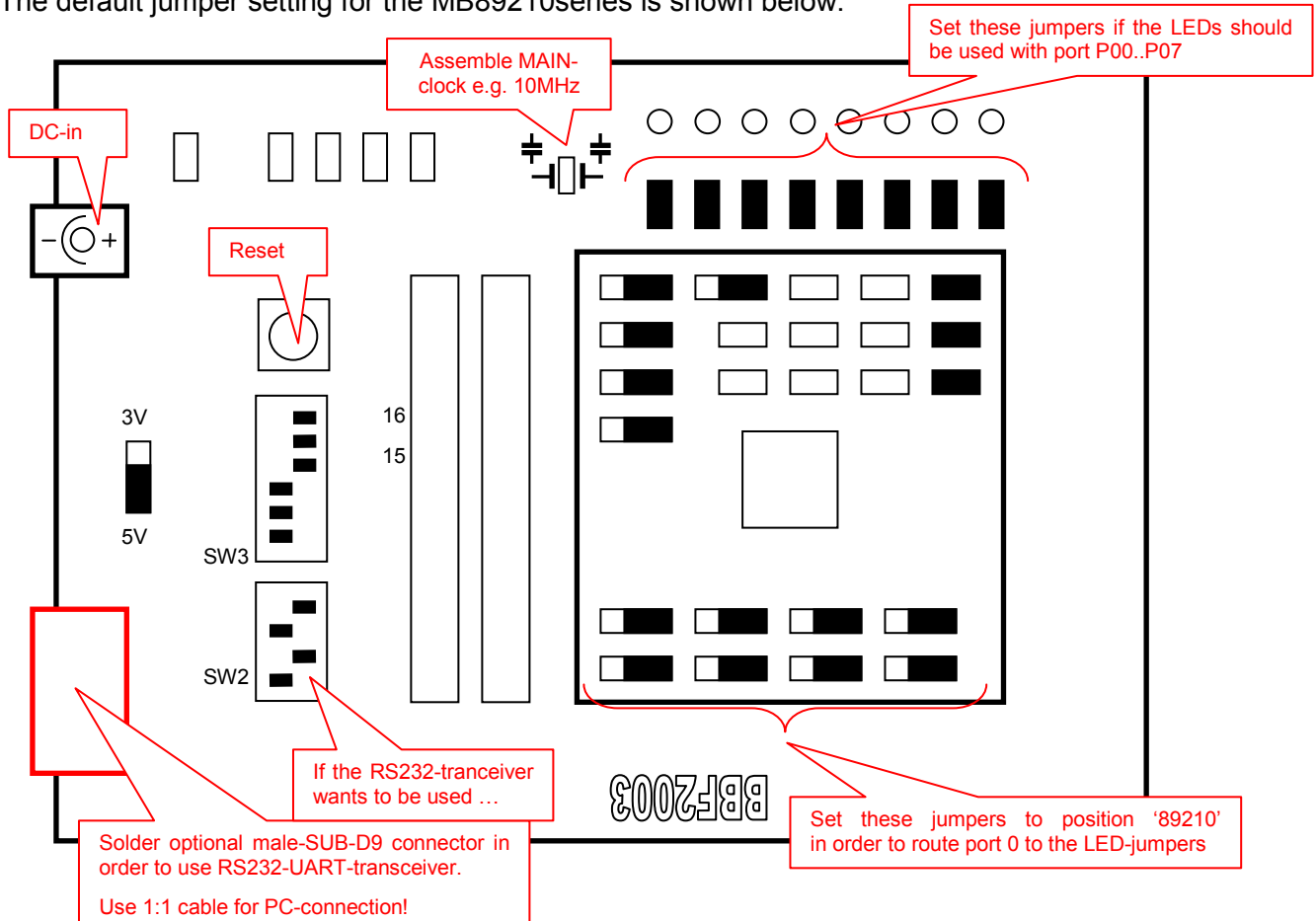

On the main board close the jumpers JP0 to JP7 (if the LEDs on the main board want to be used), set JP10 to +5V position.

Set Dip-SW2 to (1:ON, 2:OFF, 3:ON, 4:OFF) and Dip-SW3 to (1: ON, 2:ON, 3:ON, 4:OFF, 5:OFF, 6:OFF).

On the daughter board set the jumpers AVCC, RST, X1, X0, MODE and P00 to P07 (if the LEDs on the main board want to be used) to position 89210 and close the jumpers VSS1, VSS2, AVSS.

Use the probe cable MB2144-203 to connect the evaluation system to the emulator-system.

2.1 Optional Sub-D9 connector for RS232-UART

A Sub-D9 male connector can be soldered to position CN3 on the main board. By use of a standard 1:1 female/female cable the main-board can be connected to the COM port of the PC.

In order to use the UART of the MB89210 device with the on-board RS232-transceiver, two connections have to be wired manually:

Connect SOT and LUO on the daughter board as shown below.

Connect SIN and LUI on the daughter board as shown below.

Set Dip-SW2 to (1:ON, 2:OFF, 3:ON, 4:OFF).

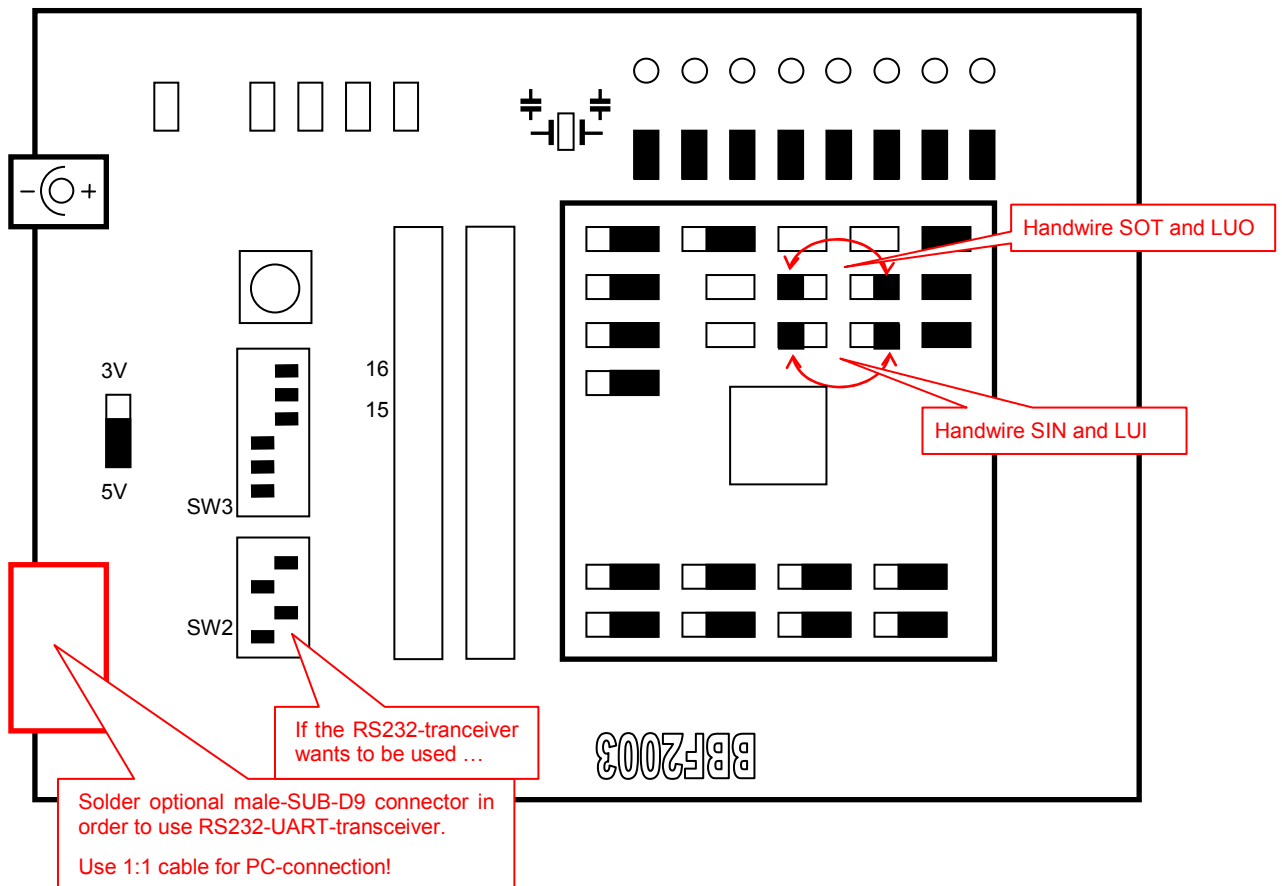

2.2 Using the LIN-interface

The UART of the MB89210series supports the LIN-protocol. A LIN-transceiver is available on the evaluation board. Set the jumpers shown below in order to use the LIN-interface

The jumpers LUO, LUI and LUC have to be shortcut on the daughter board, as well as the jumpers LIN-RxD, LIN-TxD and LNP on the main board.

Do not connect the jumper LMP of the main board, because the MB89210series does not support the master bus-mode.

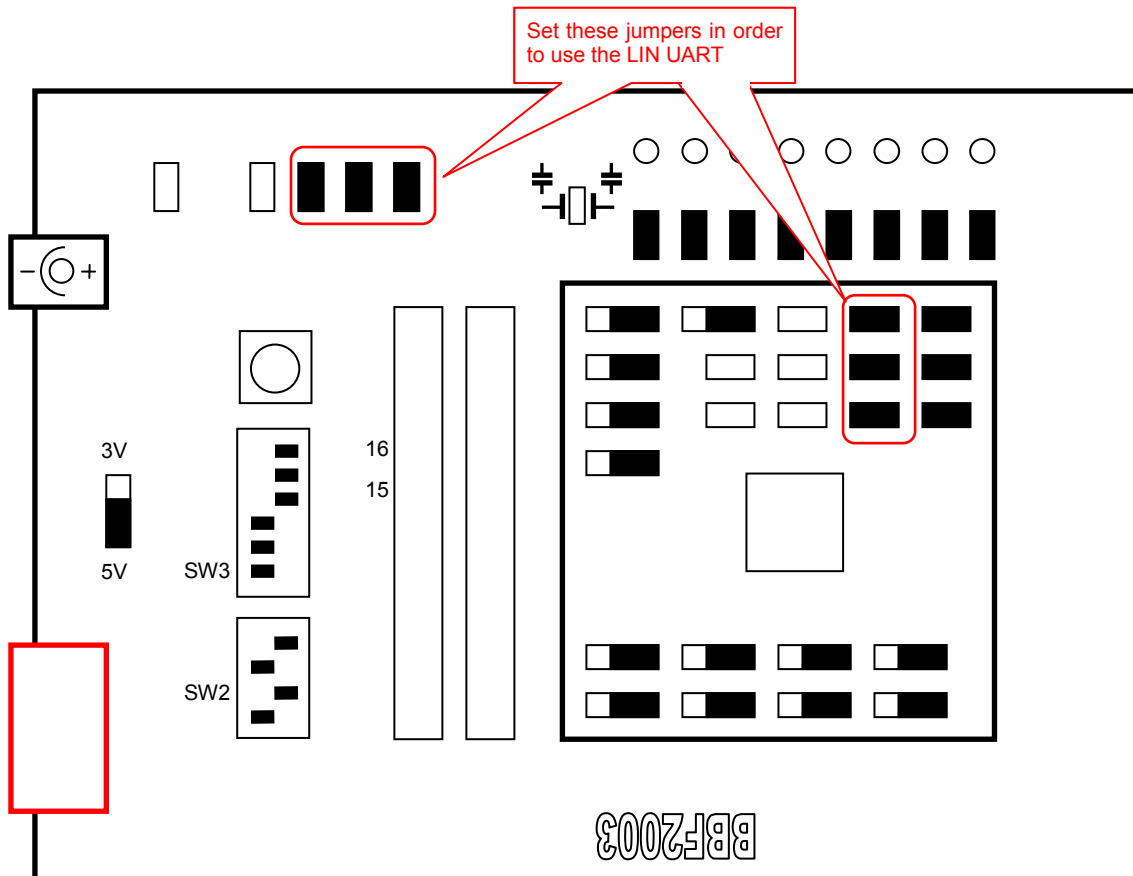

Take care to enable the on board LIN-transceiver by setting the signal LUC to 'high' level. The signal LUC is controlled by port P17:

```
DDR1_D17 = 1;    // enable LIN-transceiver
PDR1_P17 = 1;    // set Jumper LUC
```

NOTE:

LIN-interface and RS232-interface cannot be used at the same time, because the MB89210series supports only one UART that can be directed either to the LIN- or to the RS232-interface!

3 Software

On our website <http://www.fme.gsdc.de/gsd.htm> a template project as well as some example projects regarding the peripheral resources of the MB89210series are available.

Please have a look to the subfolder <http://www.fme.gsdc.de/products/samples.htm>

3.1 New project

In order to start a new user-project the template project of the MB89210series should be used always. This project includes the startup code, header files and vector table for the MB89210series.

Copy the folder 'Template' within the example-folder and rename 'Copy of Template' into 'my_application'.

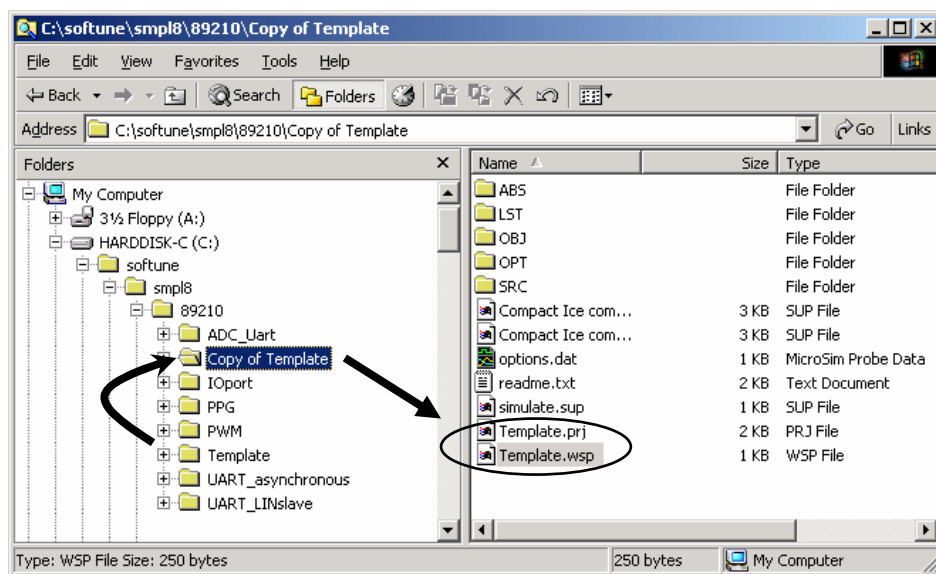

Enter 'my_application'-folder and rename 'template.prj' into 'my_application.prj' and 'template.wsp' into 'my_application.wsp'

Edit 'my_application.prj' and rename the symbol 'template' into 'my_application'.

Edit 'my_application.wsp' and rename the symbol 'template' into 'my_application'.

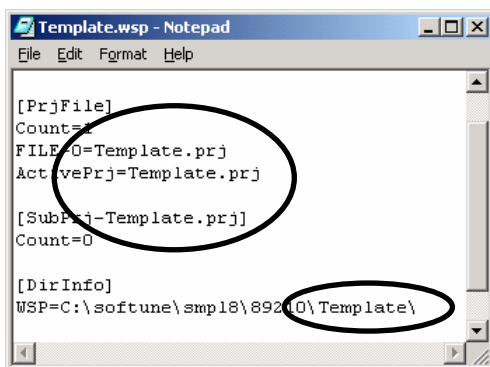

my_application.wsp

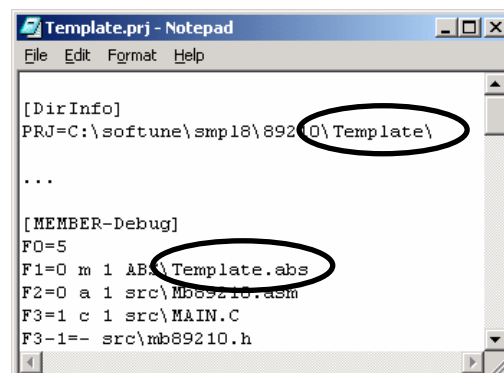

my_application.prj

Start Softune Workbench and open your project 'my_application.wsp':

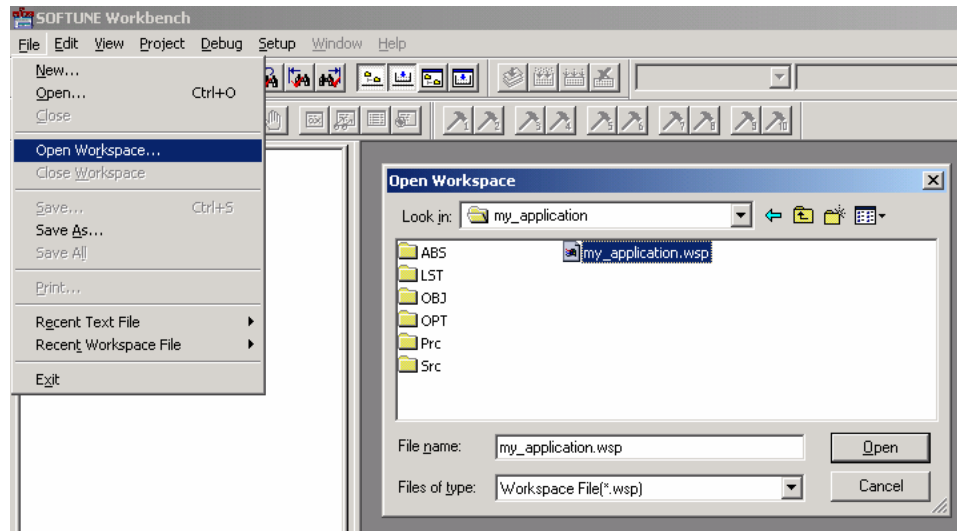

Write your application code:

- Start.asm : Startup code
- Vector.c : Vector table
- Main.c : Your application

Compile & build your project.

The generated MHX-file can be flashed into the Flash-device; the ABS-file can be used for emulation and simulation.

3.2 Flash programming

The Flash devices of the MB89210series, e.g. MB89F217 have a burn-in bootloader. By this bootloader the internal flash can be programmed via the COM-port of a PC.

3.2.1 Hardware

In order to select the asynchronous burn-in bootloader the microcontroller port pin P07 has to be connected to GND, P30 and MODA have to be connected to VCC (see table and schematic below).

Pin	MB89F217 FPT-48P-M13	Connect to
MOD0	37	VSS
MOD1	38	VSS
MODA	1	VCC (for programming only) GND (for 'RUN' mode)
UO	22	PC RxD via RS232 transceiver
UI	23	PC TxD via RS232 transceiver
P07	47	VSS (for programming only)
P30	11	VCC (for programming only)
VSS	8, 19, 43	GND
VCC	42	VCC
X0, X1	10, 9	Crystal (e.g. 10MHz)
/RST	2	Pull-up resistor to high, Switch-button to VSS

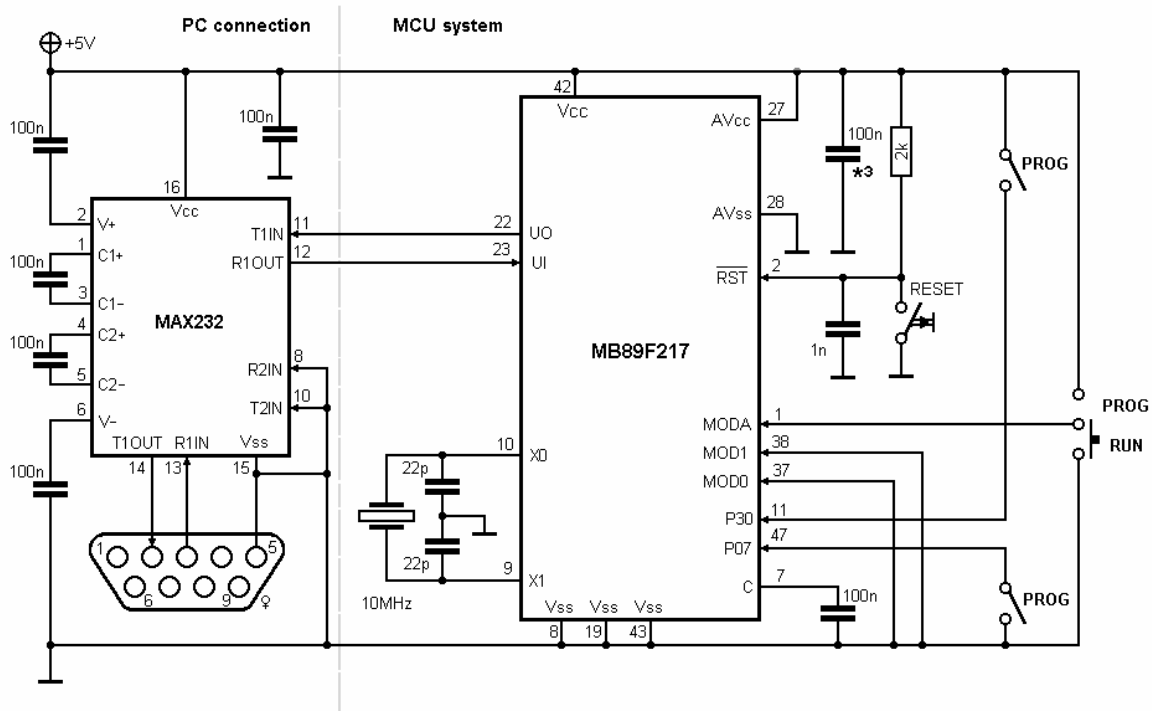

3.2.2 Software

Install the latest version of the 8bit Fujitsu Flash MCU Programmer, which should be version V01L08 or newer.

Select the Target Microcontroller [MB89F217] and the crystal frequency depending on your external crystal [e.g.: 10MHz].

Select the Hex File (ABS/*.MHX) of your project.

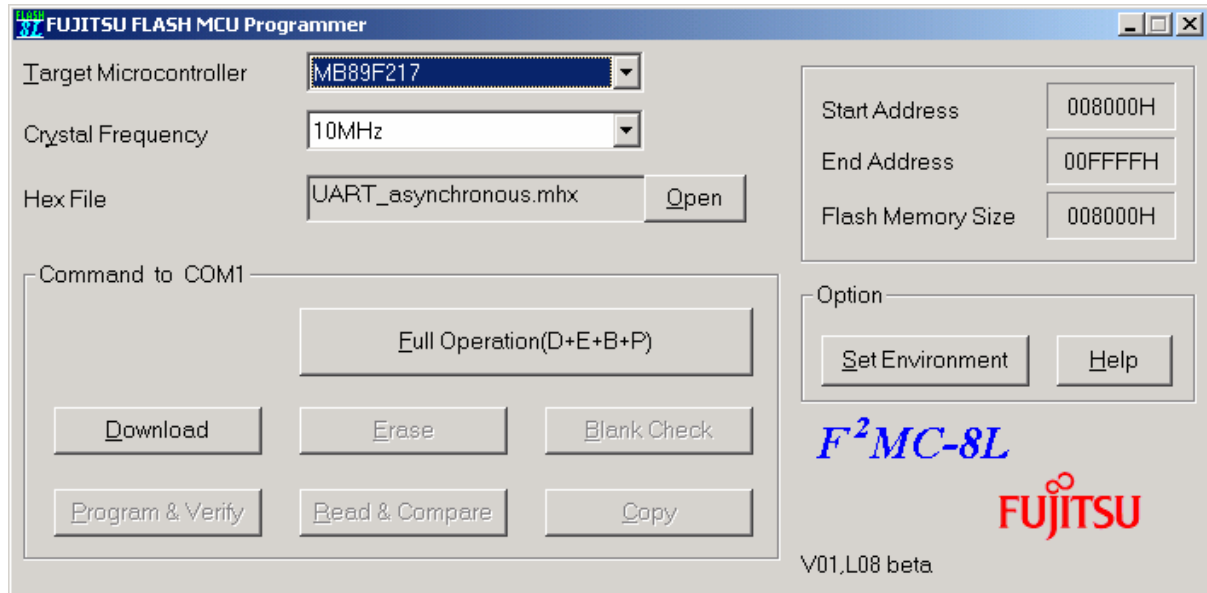

Take care that the asynchronous burn-in bootloader of the microcontroller is selected (P07='L', P30 = MODA = 'H').

Press "Full Operation" and reset your target system when prompted.

After the device is programmed successfully, select the 'RUN' mode ((P07=open, P30 = open, MODA = 'L') and reset the target system. The application should start automatically.

