

# Application Note

## Connecting standard LCD modules to the MB89630 series

© Fujitsu Mikroelektronik GmbH

15.1.1997

Vers. 1.0 by M.Mierse

**In many applications, standard LCD modules are used. Such modules feature a dedicated controller on board to drive a dot matrix with a high segment count. Furthermore this controller provides a parallel interface to establish communication with other devices. In the majority of cases this is a HD44780A00 (or a compatible one).**

LCD standard display modules come in many sizes and shapes. Most of them are twisted nematic reflective displays which outputs one or more lines of alphanumeric characters. Each character is formed in a 5 by 8 matrix of dots. The intended applications are computer peripherals, word processors, facsimile machines, telecommunications systems, instruments, point-of-sale terminals, etc.

### How LCD's work

As the name implies a liquid crystal is a compound that flows like a liquid but has a crystalline order in the arrangement of their molecules. In a display, these crystals keep their long axes aligned due to intermolecular forces. So by controlling the alignment, one effectively controls the optical properties as well as the ability of the crystals to affect the transmission of light.

In a display, the liquid crystal material is sealed between two glass plates, one bearing transistors to control the electrode (row electrodes) of each cell, the other bearing colour filters and an electrode (column electrodes) to complete the circuit. Polarizers in the front and the rear complete the array which is illuminated from behind.

### Example application

Fig. 1 shows how to connect a standard LCD module to the MB89637 EVAKIT. The device is connected to Port 3 of the EVAKIT in a 4-bit mode, so only 7 portpins are used (4 Data-lines and 3 Control-lines). The port output type has to be CMOS push-pull. Every data byte is transmitted in 2 nibbles using a handshake protocol. Four different display types were used to test the application.

To activate the LCD-controller, an initial sequence has to be sent to the module. This procedure sets the device into the correct bus-mode and clears the internal RAM. Typical data transfer between the controller and the LCD then consists of commands (listed in table 2) and data (ASCII-compatible character set, see table 3). Example Code was written in ASM and C.

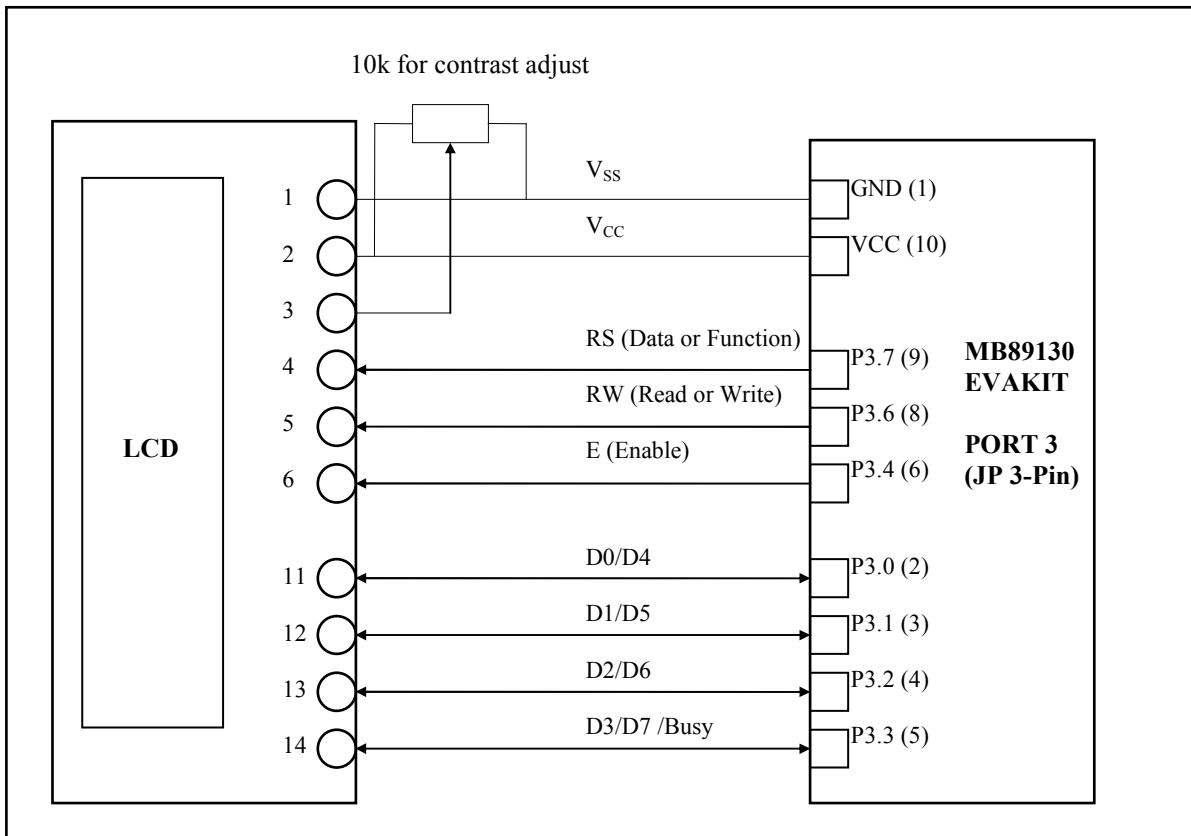

**Fig. 1 : Connecting a standard LCD to the 8-bit-EVAKIT**

The pin assignment shown in Table 1 is the industry standard for character LCD-modules (except those with more than 80 characters). To be sure always check the manufacturers datasheet! The displays can be used in a 8-bit or a 4-bit-interface mode.

Pin	Symbol	Level	I/O-Function	Function (8-bit mode)	Function (4-bit mode)
1	Vss	-	-	Power supply (GND)	Power supply (GND)
2	Vcc	-	-	Power supply (+5V)	Power supply (+5V)
3	Vee	-	-	Contrast adjust	Contrast adjust
4	RS	0/1	I	0 = Instruction 1 = data	0 = Instruction 1 = data
5	R/W	0/1	I	0 = Write to 1=Read from LCD	0 = Write to 1=Read from LCD
6	E	1 → 0	I	Enable signal	Enable signal
7	DB0	0/1	I/O	Data bus line 0 (LSB)	not used
8	DB1	0/1	I/O	Data bus line 1	not used
9	DB2	0/1	I/O	Data bus line 2	not used
10	DB3	0/1	I/O	Data bus line 3	not used
11	DB4	0/1	I/O	Data bus line 4	Data bus line 0 (LSB) and 4
12	DB5	0/1	I/O	Data bus line 5	Data bus line 1 and 5
13	DB6	0/1	I/O	Data bus line 6	Data bus line 2 and 6
14	DB7	0/1	I/O	Data bus line 7 (MSB)	Data bus line 3 and 7 (MSB)

**Table 1 : Pin assignment**

Instruction	RS	R W	DB 7	DB 6	DB 5	DB 4	DB 3	DB 2	DB 1	DB 0	Description	Execution time**
Clear display	0	0	0	0	0	0	0	0	0	1	Clears display and returns cursor home	1.64ms
Cursor home	0	0	0	0	0	0	0	0	1	*	Returns cursor to home position	1.64ms
Entry mode set	0	0	0	0	0	0	0	1	ID	S	Sets cursor move direction (I/D),	40µs
Display On/Off control	0	0	0	0	0	0	1	D	C	B	Sets On/Off of all display (D), cursor	40µs
Cursor/ display shift	0	0	0	0	0	1	SL	RL	*	*	Sets cursor-move or display-shift	40µs
Function set	0	0	0	0	1	DL	N	F	*	*	Sets interface data length (DL), number	40µs
Set CGRAM address	0	0	0	1	a	a	a	a	a	a	Sets the CGRAM address.	40µs
Set DDRAM address	0	0	1	a	a	a	a	a	a	a	Sets the DDRAM address.	40µs
Read busy-flag	0	1	BF	a	a	a	a	a	a	a	Reads Busy-flag (BF) and address counter	0µs
Write to CG- or DD-RAM	1	0	d	d	d	d	d	d	d	d	Writes data to CGRAM or DDRAM.	40µs
Read from CG- or DD-RAM	1	1	d	d	d	d	d	d	d	d	Reads data from CGRAM or DDRAM.	40µs

**Table 2 : HD44780 instruction set**

Remarks:

DDRAM = Display Data RAM. CGRAM = Character Generator RAM. DDRAM address corresponds to cursor position. Address Counter used for both DDRAM and CGRAM. \* = Don't care. \*\* = Based on Fosc = 250khz. a=address. d=data

	00000001111111	
	00011110011111	
	01100111100111	
	01010101010101	
xxxx0000	@P`P -?EOP	
xxxx0001	!1AQa. 7fg3q	
xxxx0010	"2BRbr`r'iyzB0	
xxxx0011	#3CScsJGfEs	
xxxx0100	\$4DTdt\,EtPWR	
xxxx0101	%5EUeu. 7+10ü	
xxxx0110	&6FVfvv7k20pZ	
xxxx0111	'7GW9w77z7qπ	
xxxx1000	(8Hxhxix7UJx	
xxxx1001	)9IYiy7JL'U	
xxxx1010	*:JZjzEJhVif	
xxxx1011	+;K[k(7SE0*7	
xxxx1100	,<L#11737777	
xxxx1101	-=M]m}u^7777	
xxxx1110	.>N^77777777	
xxxx1111	/?Q_07777777	

**Table 3 : Character Set**